

Transport heavy loads effortlessly

Maini's floor transportation range enables effortless transfer of heavy loads in your shop floors and warehouses. This range includes the quintessential **Electric Pallet Trucks** and **Electric Platform Trucks**, designed to **enhance productivity, ensure safety and optimize returns**. Streamlined design and small turning radius makes it **ideal** for operating in **narrow passageways**. **Ease of maintenance** makes it your best choice for the long run.

With Maini in your warehouse you can transport heavy loads easily, ergonomically, efficiently and swiftly.

Easy Operation

Convenient operations with simple controls

Enhanced Safety

Safety switch cuts off power supply and actuates parking brake simultaneously

Speed Control

Microprocessor based motor controller for precise and step-less throttle control

Awesome Ergonomics

Ergonomic handle and stand on platform provides increased driver comfort

FEATURES

Ergonomic handle ensuring total operator control



Easy access for service & maintenance

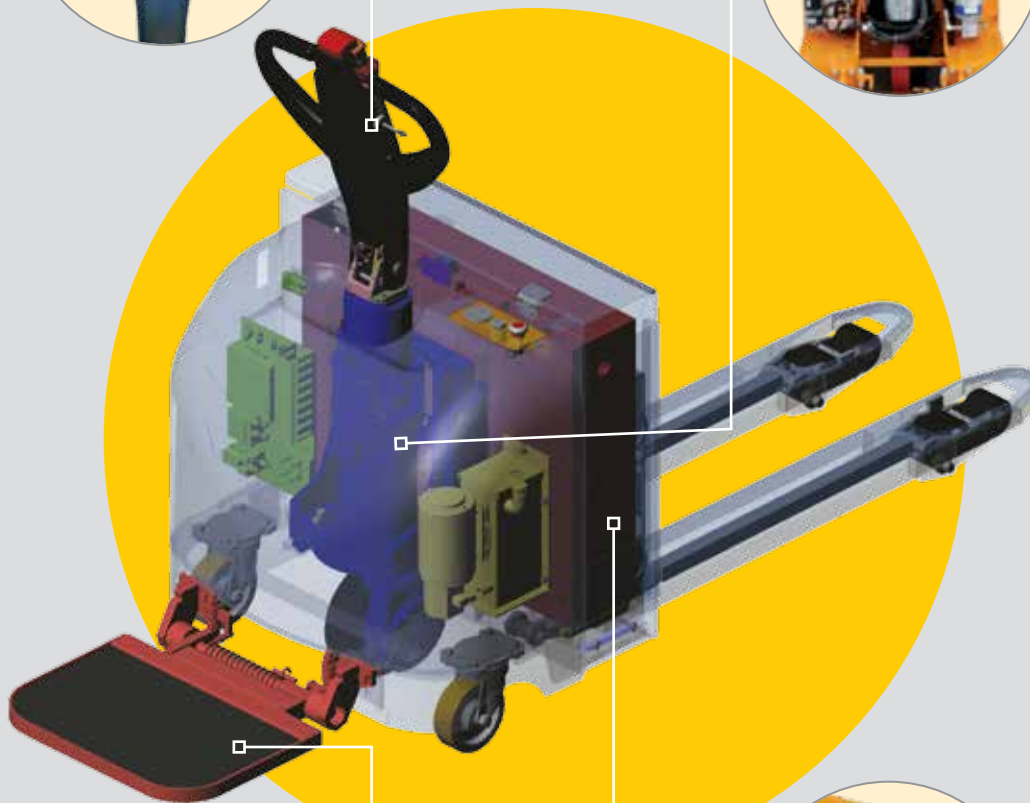

Vibration Damped stand on platform for optimum rider comfort



Battery with roller for quick battery change



TECHNICAL SPECIFICATIONS SP SERIES

Features	Unit	SP20	SP25	SP36	SP50
Capacity	Kg	2000	2500	3600	5000
Pump Motor	Kw	2.0	2.0	2.0	2.0
Drive Motor	Kw	1.5	1.5	1.5	2.5
Max. Travel Speed – Unladen / Laden	km/hr	4/4	7.5/5.5	5.5/4.5	4.5/3.5
Gradeability – Unladen / Laden	%	10/5	10/5	10/5	10/3
Max Travel Distance on Gradient	m	20	20	15	15
Lifting Speed – Unladen / Laden	m/s	1.5/2	1.9/2	2.5/4.3	2.5/4
Lowering Speed – Unladen / Laden	m/s	15/5.5	15/5.5	22/5.8	22/3
Battery Capacity	V,Ah	24,162	24,244	24,330	24,330
Net Weight – Without / With Battery	Kg	450/620	450/735	580/865	605/890
Wheels (Polyurethane)					
Drive	mm	230x75	230x75	230x75	230x75
Castors	mm	150x50	150x50	150x50	150x50
Load	mm	82x70	82x70	82x70	82x70

ELECTRIC PALLET TRUCK SP SERIES



SP20 / SP25 / SP36 / SP50

Model: SP Series

Capacity: 2000kg - 5000kg

- Horizontal transport of goods
- Ideal for high intensity movement
- Compact design
- Can be used with a dock leveler for container loading

Model	L1	L2	X	Y
SP20 / 25	1150	850	90	205
SP36 / 50	1220	900	90	220

DIMENSIONAL SPECIFICATION

SP20 / 25

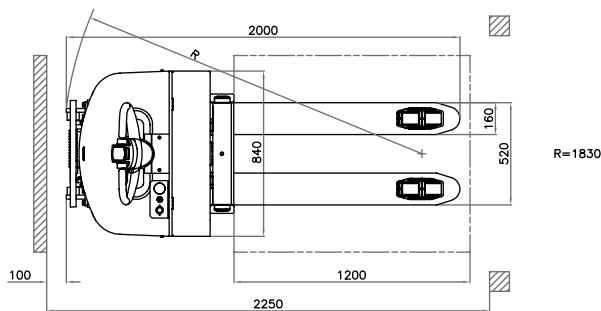

SP36 / 50

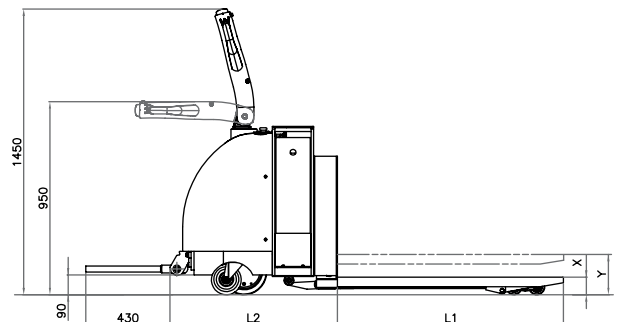
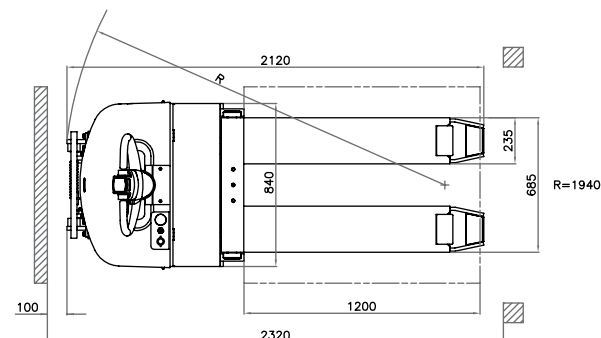

All dimensions in mm.
Materials and specifications are subject to change without notice

ELECTRIC PLATFORM TRUCK: EPT / EPTP SERIES



Model: EPT Series

Capacity: 300kg / 500kg

- AC technology
- Perfect for driving in stores & warehouses
- Ideal for transporting non-standard non-palletized loads between locations
- High ground clearance and solid rubber tyres
- Wide ladder steps for order picking in high shelves

Options

- Battery discharge indicator with hour meter
- Double platform for enhanced productivity
- Stepless electronic speed controller
- Cage enclosure

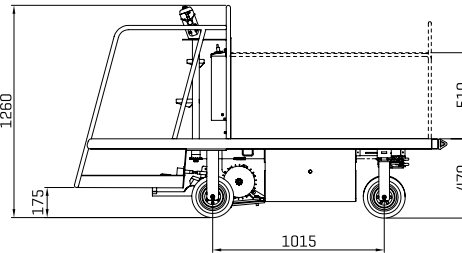
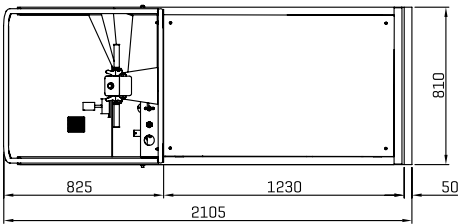

Model: EPT 5P

Capacity: 500kg

EPT 5P is an order picker version. The platform has a scissor lift mounted enabling a 2100 mm lift from the ground. This enables easy picking of light loads. Ideal for small stores and spare parts warehouses.

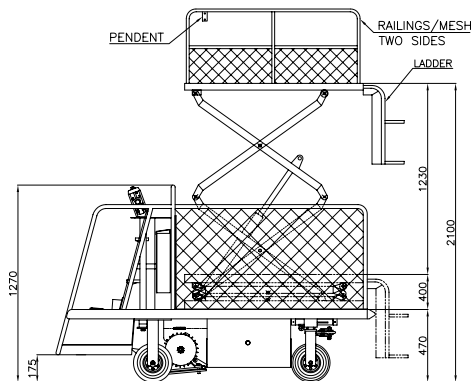

All dimensions in mm.
Materials and specifications are subject to change without notice

